

This drawing is the property of H3 Plastics Company.
The information is strictly confidential and is not to be used
in any way without the prior written consent of authorised
representatives of H3 Plastics Company.

Notes: *Fill level for still water at 84° C*
Dimensions and positions of bottom logos may change
** Informative dimensions*

Cavity nr.

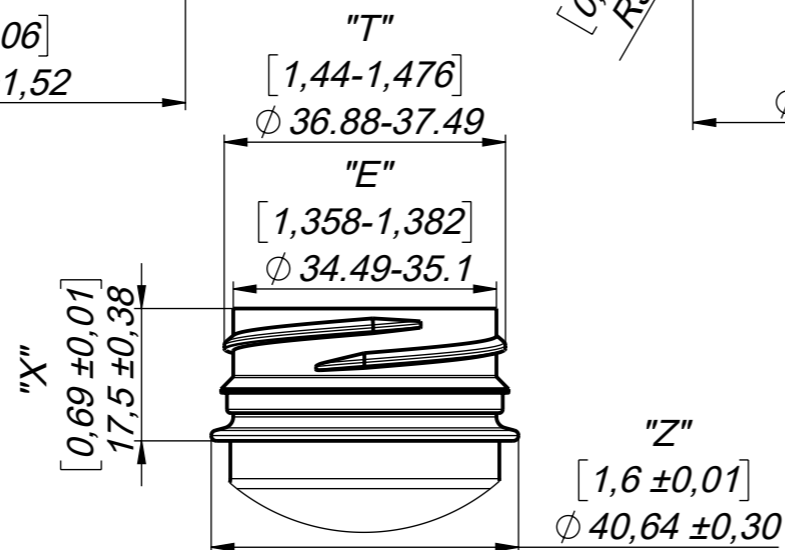
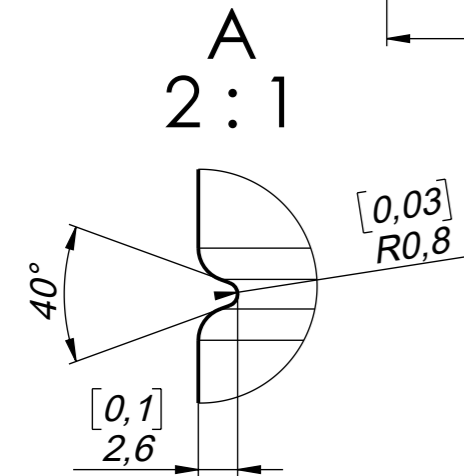
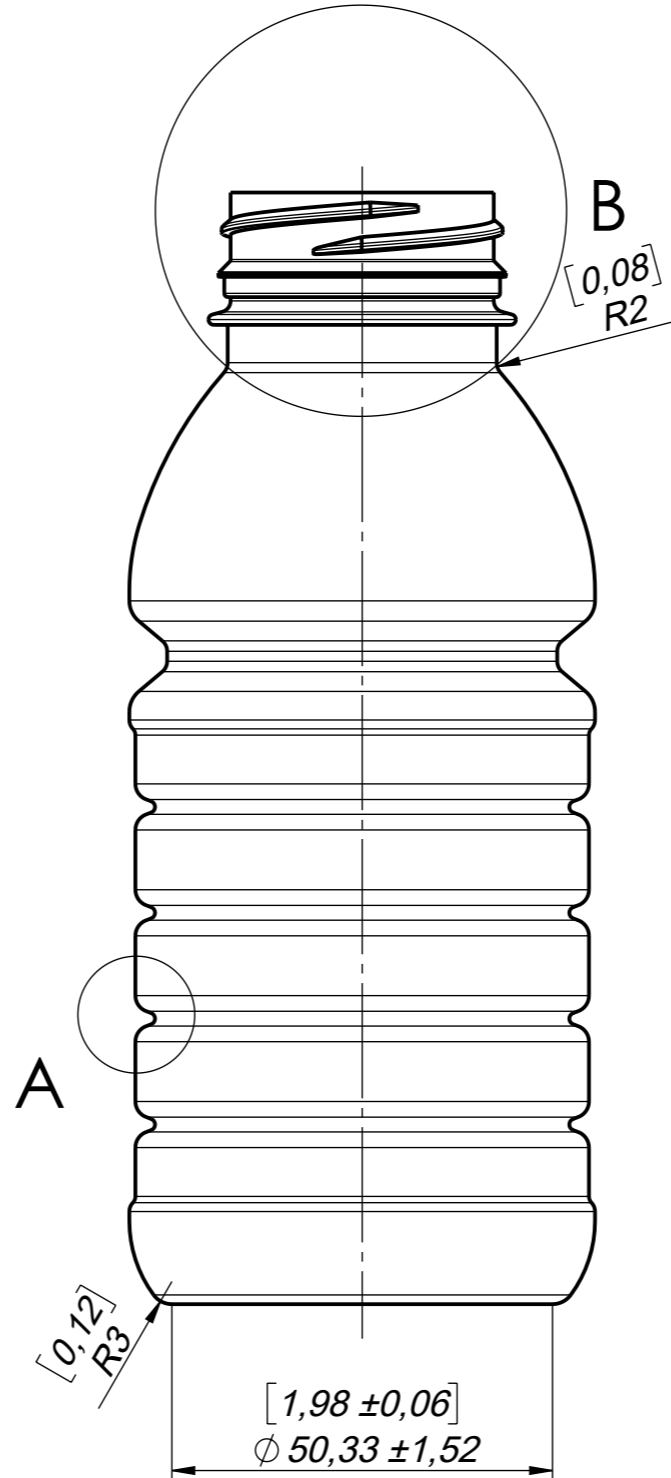
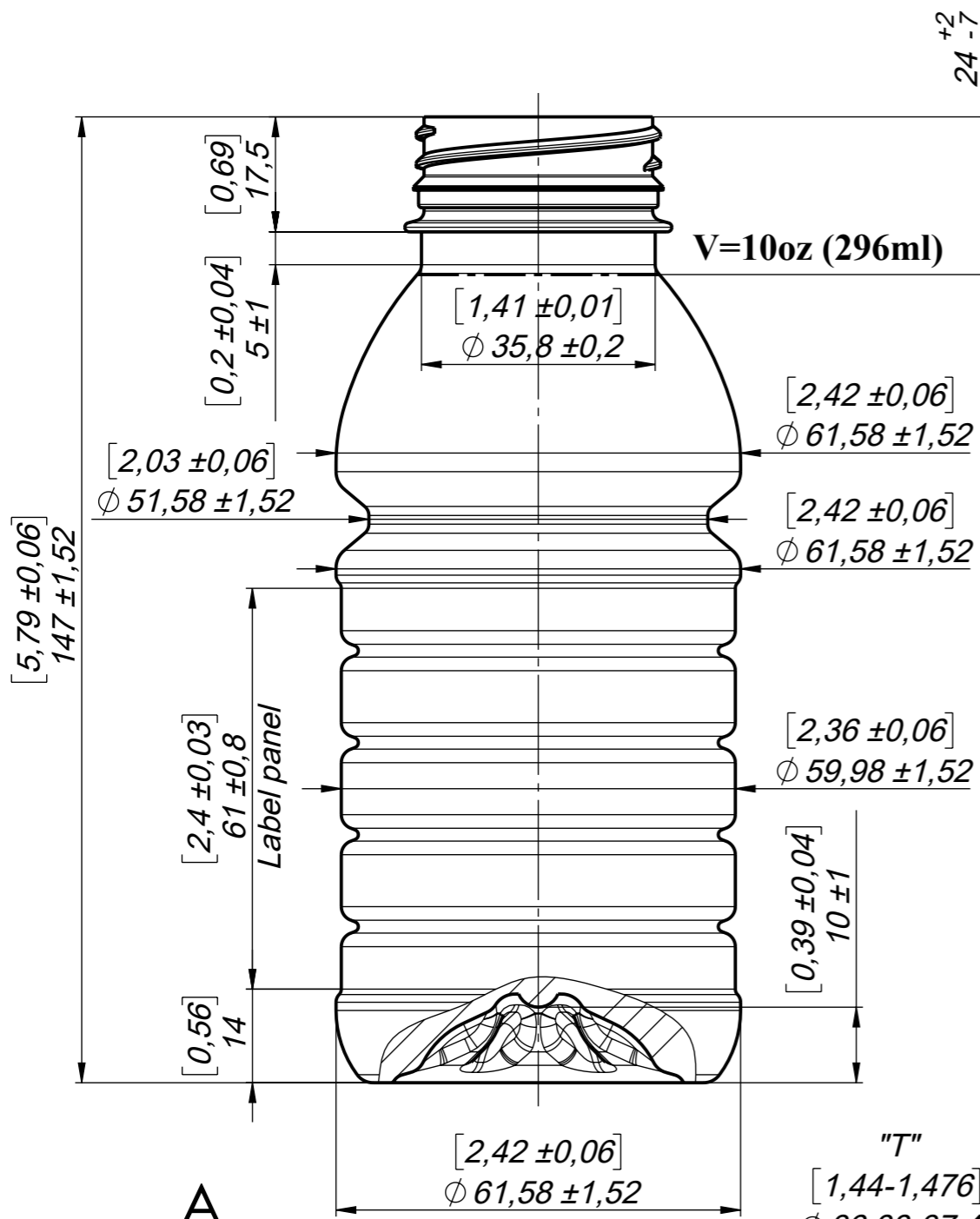
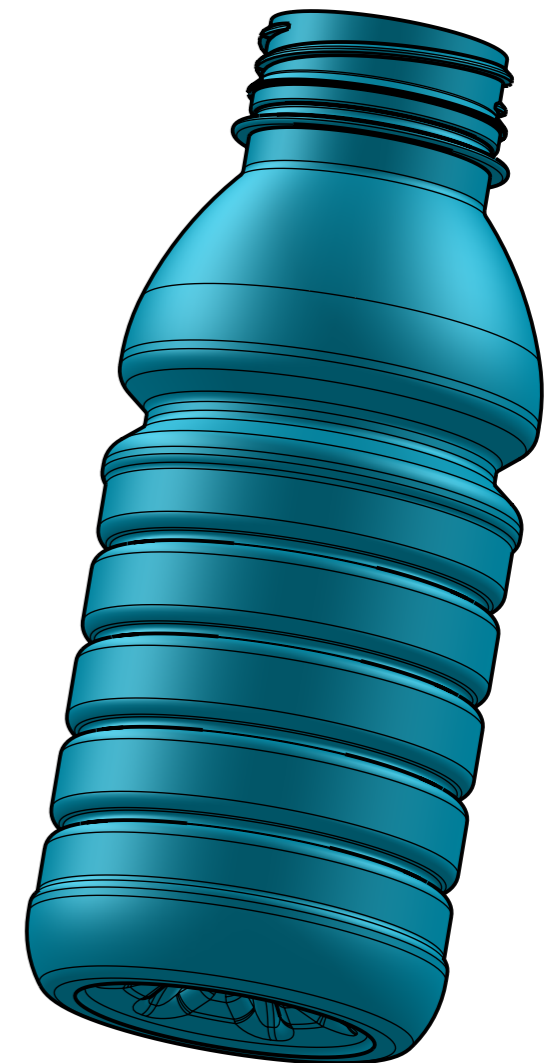
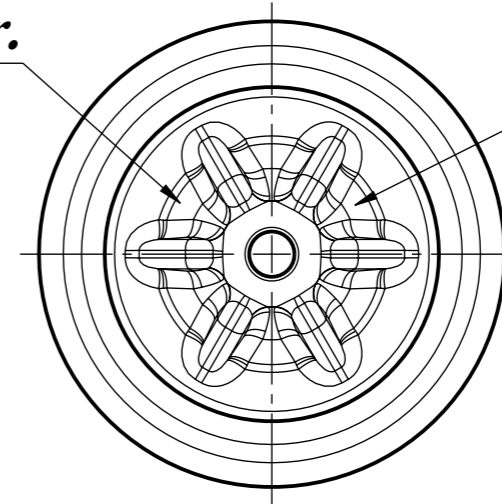

Weight	24,75g ± 1g	Internal Pressure Tolerance	<0.5 BAR	Neck Standard	38mm 2 str	Scale	1:1
Production machinery	Confirmed	Fillpoint Volume	10oz (296ml)	Brimfull Volume	10,75oz ± 0,3oz (318ml ± 9ml)	Revision	
Owner	H3	Prepared	VL	Description		Dwg. No.	
		Approved by		10oz (296ml)		D1228-5	
				Date	2022-11-30	Lang.	It
				Sheet	1/1		